

**VS24,VS27,VS30,VS36,SB36**

**ASSEMBLY INSTRUCTIONS**

Getting started:

prepare a protection layer, a screwdriver

STEP 1: Joint side panel with back panel

STEP 2: Joint bottom panel with side panel

STEP 3: Joint side panel with bottom & back panel





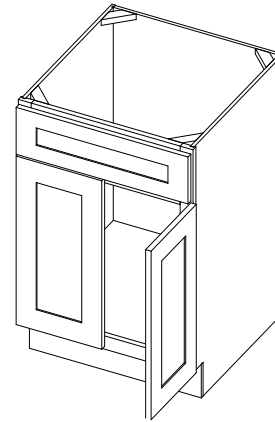

STEP 4: Attach frame on and toekick board

STEP 5: Attach the plastic block on the top corner, and put on the adjustable shelf

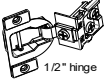
STEP 6: Fix door&drawer head onto the frame and adjust the cover-space

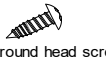
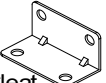

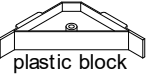
PARTS LIST		
NO.	Description	QTY
A	BACK PANEL	1
B	SIDE PANEL	2
C	TOP&BOTTOM PANEL	1
D	TOE KICK	1
E	FACE FRAME	1
F	CABINETS DOOR	2
G	DRAWER HEAD	1

8	1/2" HINGE	4	 1/2" hinge
7	3/4" ROUND HEAD SCREW	4	 3/4" round head screw
6	BUMPER	4	 Bumper
5	9/16" ROUND HEAD SCREW	44	 9/16" round head screw
4	CLEAT	11	 Cleat
3	1" FLAT HEAD SCREW FOR CARCASS	3	 1" flat head screw
2	Plastic Block	4	 plastic block
1	9/16" flat head screw	8	 9/16" flat head screw
NO.	Description	QTY	PICTURE

**HARDWARE LIST**

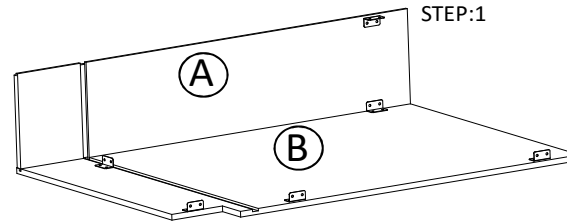

STEP:1

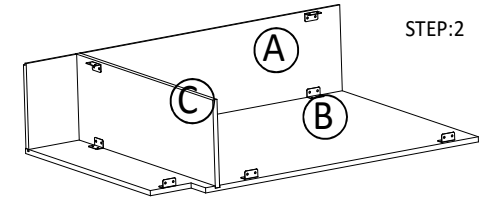

STEP:2

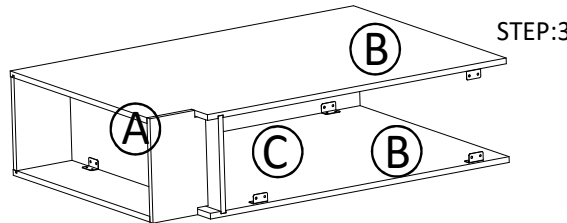

STEP:3

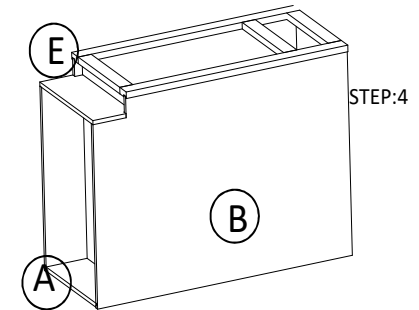

STEP:4

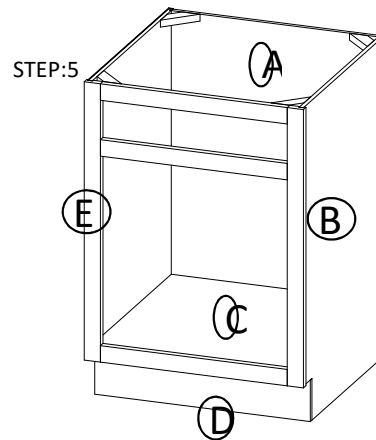

STEP:5

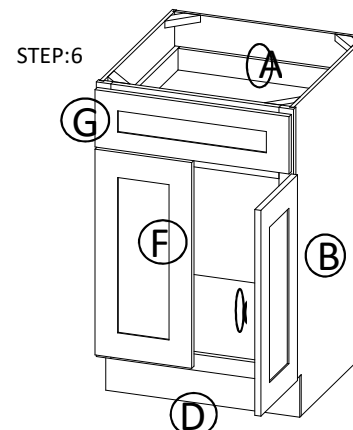

STEP:6