

**B24,B27,B30,B33,B36,B42**

**ASSEMBLY INSTRUCTIONS**

**Getting started:**

prepare a protection layer, a screwdriver

STEP 1: Joint side panel with back panel

STEP 2: Joint bottom panel with side panel

STEP 3: Joint side panel with bottom & back panel

STEP 4: Attach frame on and toekick board







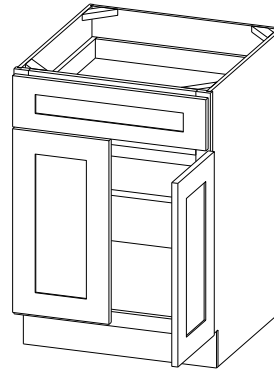



STEP 5: Joint the drawer together, then install the drawer guide.

STEP 6: Attach the plastic block on the top corner, and put on the adjustable shelf

STEP 7: Fix drawer head on the drawer front and fix door onto the frame and adjust the cover-space



PARTS LIST		
NO.	Description	QTY
A	BACK PANEL	1
B	SIDE PANEL	2
C	TOP&BOTTOM PANEL	1
D	TOE KICK	1
E	FACE FRAME	1
F	DRAWER BOX FRONT AND BACK	2
G	DRAWER BOX SIDE	2
H	DRAWER BOX BOTTOM	1
I	ADJUSTABLE SHELF	1
J	DRAWER HEAD	1
K	CABINETS DOOR	2

11	1/2" HINGE	4	
10	3/4" ROUND HEAD SCREW	4	
9	BUMPER	8	
8	1" ROUND HEAD SCREW	4	
7	Epoxy Slide	1	
6	SHELF CLIP	4	
5	9/16" ROUND HEAD SCREW	44	
4	CLEAT	11	
3	1" FLAT HEAD SCREW FOR CARCASS	11	
2	Plastic Block	4	
1	9/16" flat head screw	18	
NO.	Description	QTY	PICTURE

**HARDWARE LIST**

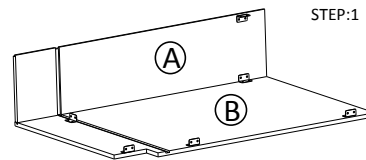

STEP:1

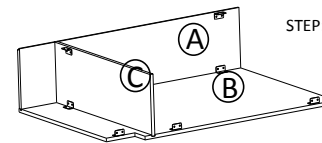

STEP:2

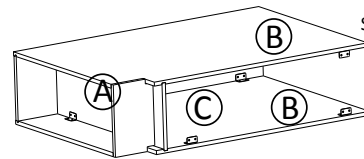

STEP:3

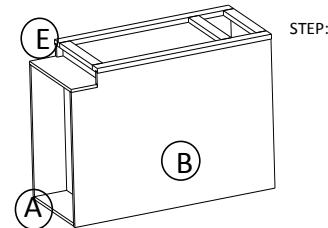

STEP:4

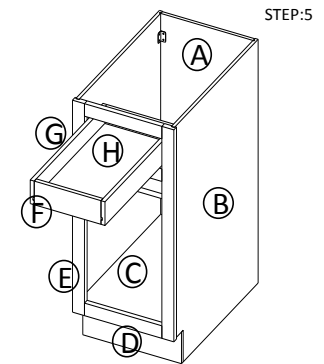

STEP:5

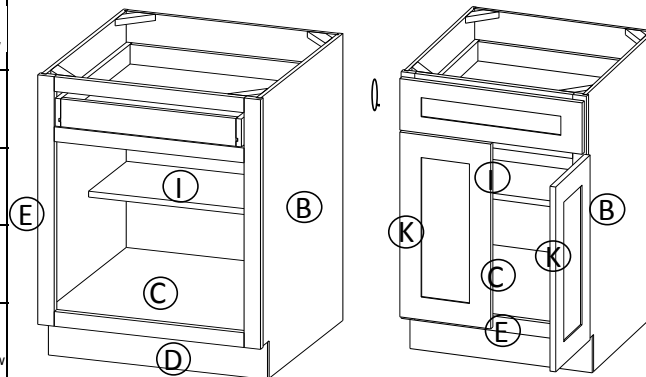

**Epoxy sidemount drawer runners**

