

# BEC24

## ASSEMBLY INSTRUCTIONS

### Getting started:

prepare a protection layer, a screwdriver

STEP 1: Joint two side panel together

STEP 2: Attach top panel

STEP 3: Attach bottom panel

STEP 4: Attach toekick on

STEP 5: Attach frame on





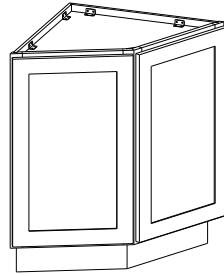

STEP 6: Put on the adjustable shelves

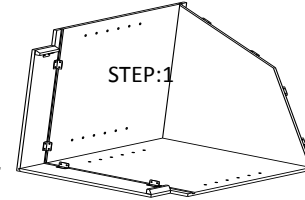
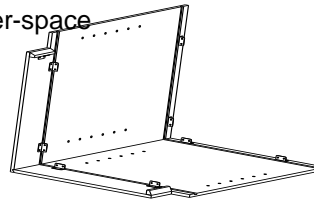
STEP 7: Hinge the door onto the face frame and adjust the cover-space

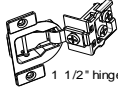

PARTS LIST		
NO.	Description	QTY
A	SIDE PANEL	1
B	SIDE PANEL	1
C	TOP&BOTTOM PANEL	2
D	TOE KICK	2
E	FACE FRAME	2
F	ADJUSTABLE SHELF	2
G	CABINETS DOOR	2

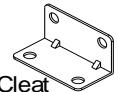

9	Wood Block	2	
8	135 DEGREE ANGLE	3	 135° angle
7	1/2" HINGE	4	 1 1/2" hinge
6	3/4" ROUND HEAD SCREW	4	 3/4" round head screw
5	BUMPER	4	 Bumper
4	SHELF CLIP	12	 Shelf clip
3	9/16" ROUND HEAD SCREW	78	 9/16" round head screw
2	CLEAT	18	 Cleat
1	1" FLAT HEAD SCREW FOR CARCASS	5	 1" flat head screw

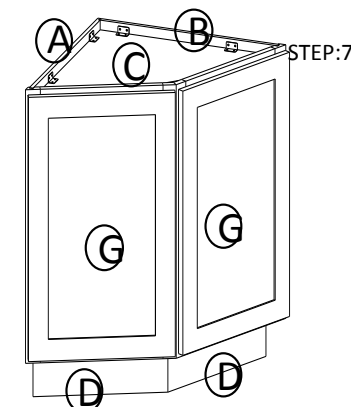
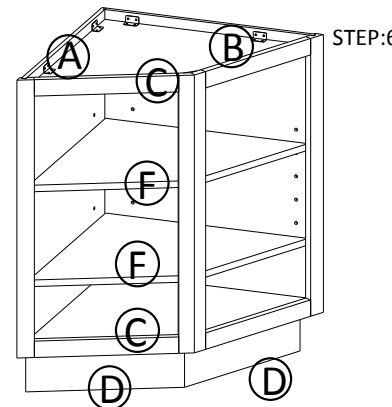
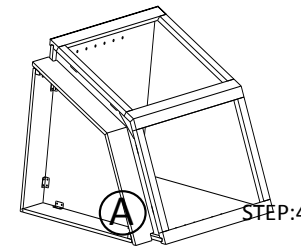
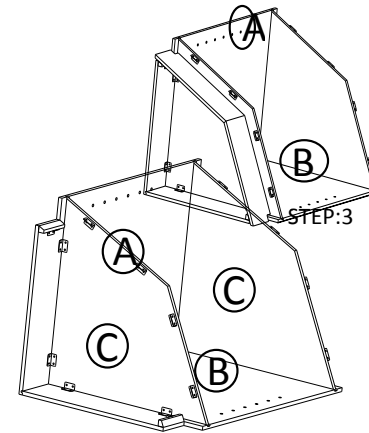

NO.	Description	QTY	PICTURE
-----	-------------	-----	---------

### HARDWARE LIST