

# DCW2430,DCW2436,DCW2442

## ASSEMBLY INSTRUCTIONS

### Getting started:

prepare a protection layer, a screwdriver

STEP 1: Joint side panel with front face frame

STEP 2: Attach top panel with front face frame and side panel

STEP 3: Attach top panel with front face frame and side panel





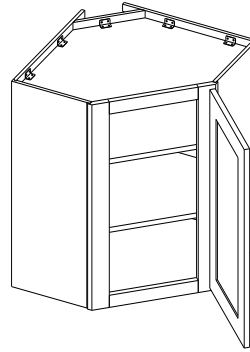

STEP 4: Attach back panel on side panel

STEP 5: Insert back panel through groove, then screw up

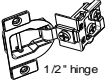
STEP 6: Hing door on to front face frame and adjust the cover-space

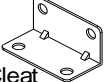

PARTS LIST		
NO.	Description	QTY
A	FACE FRAME	1
B	SIDE PANEL	2
C	TOP&BOTTOM PANEL	2
D	BACK PANEL	2
E	BACK PANEL	1
F	ADJUSTABLE SHELF	2
G	CABINETS DOOR	1

8	1/2" HINGE	2	
7	3/4" ROUND HEAD SCREW	2	
6	BUMPER	2	
5	SHELF CLIP	10	
4	9/16" ROUND HEAD SCREW	92	
3	CLEAT	22	
2	1" FLAT HEAD SCREW FOR CARCASS	6	
1	135 DEGREE ANGLE	2	
NO.	Description	QTY	PICTURE

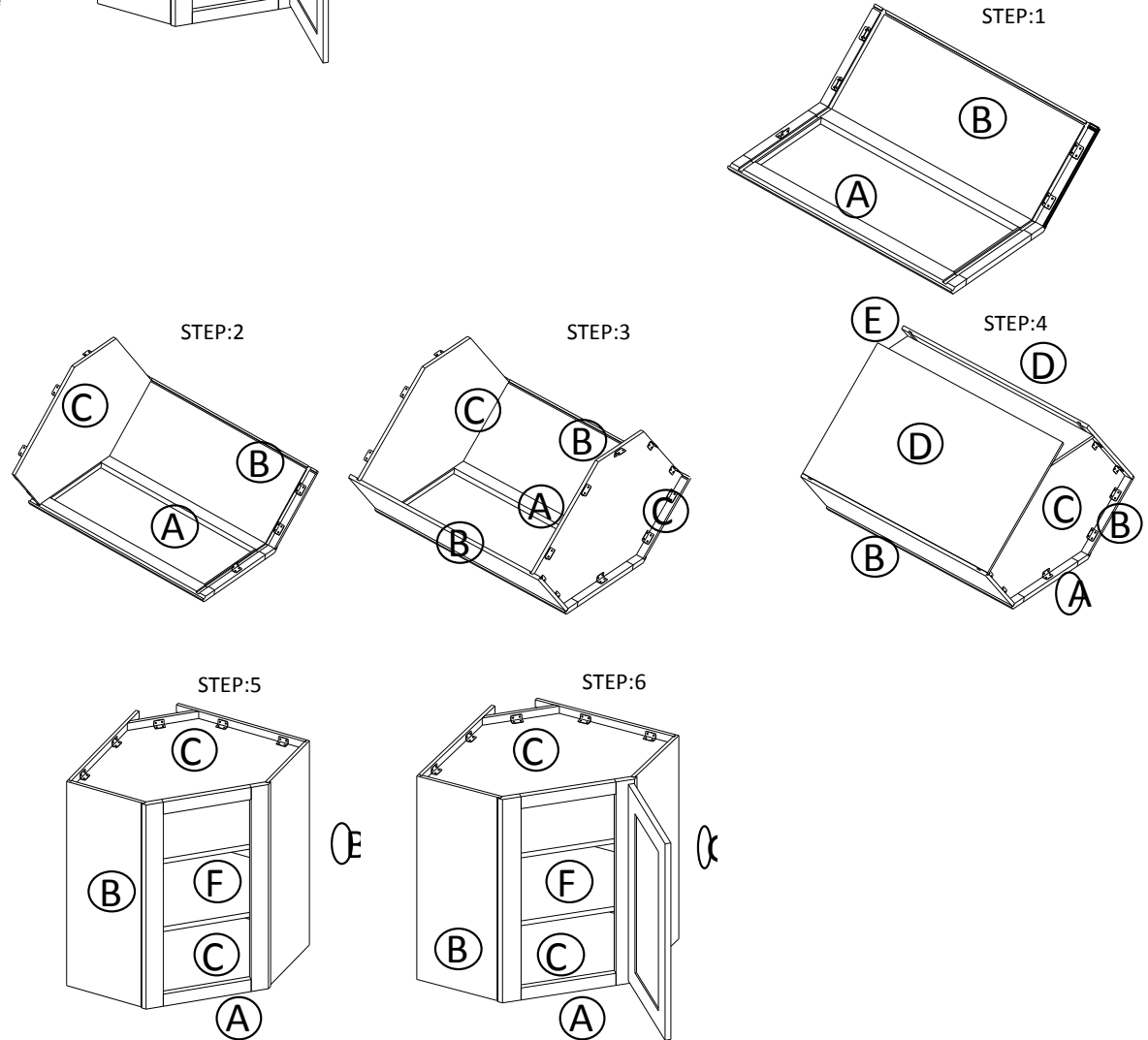

### HARDWARE LIST