

DFB18

ASSEMBLY INSTRUCTIONS

Getting started:

prepare a protection layer, a screwdriver

STEP 1: Joint side panel with back panel

STEP 2: Joint bottom panel with side panel

STEP 3: Joint side panel with bottom & back panel

STEP 4: Attach frame on and toekick board



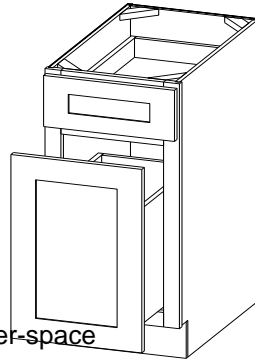

STEP 5: Attach the plastic block on the top corner

STEP 6: Joint the drawer together, then install the drawer guide

STEP 7: Fix drawer head on the drawer front and adjust the cover-space

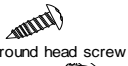
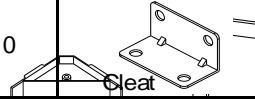
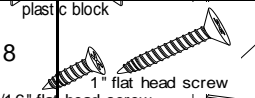
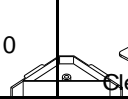

PARTS LIST		
NO.	Description	QTY
A	BACK PANEL	1
B	SIDE PANEL	2
C	TOP&BOTTOM PANEL	1
D	TOE KICK	1
E	FACE FRAME	1
F	DRAWER BOX FRONT AND BACK	4
G	DRAWER BOX SIDE	4
H	DRAWER BOX BOTTOM	2
I	DRAWER HEAD	1
J	DOOR	1

8	BUMPER	8	 Bumper
7	1" ROUND HEAD SCREW	8	 Epoxy slide 1" round head screw
6	Epoxy Slide	2	
5	9/16" ROUND HEAD SCREW	40	 9/16" round head screw
4	CLEAT	10	 Cleat
3	1" FLAT HEAD SCREW FOR CARCASS	18	 1" flat head screw
2	Plastic Block	4	 plastic block
1	9/16" flat head screw	28	 9/16" flat head screw
NO.	Description	QTY	PICTURE
HARDWARE LIST			

