

**VS24,VS27,VS30,VS36,SB36**

**ASSEMBLY INSTRUCTIONS**

**Getting started:**

prepare a protection layer, a screwdriver

STEP 1: Joint side panel with back panel

STEP 2: Joint bottom panel with side panel

STEP 3: Joint side panel with bottom & back panel



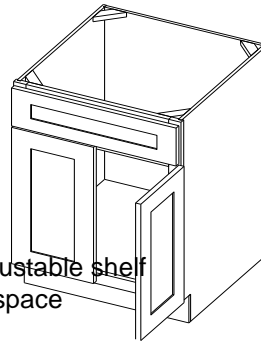

STEP 4: Attach frame on and toekick board

STEP 5: Attach the plastic block on the top corner, and put on the adjustable shelf

STEP 6: Fix door&drawer head onto the frame and adjust the cover-space

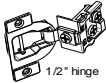

PARTS LIST		
NO.	Description	QTY
A	BACK PANEL	1
B	SIDE PANEL	2
C	TOP&BOTTOM PANEL	1
D	TOE KICK	1
E	FACE FRAME	1
F	CABINETS DOOR	2
G	DRAWER HEAD	1

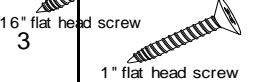
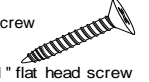
8	1/2" HINGE	4	
7	3/4" ROUND HEAD SCREW	4	
6	BUMPER	4	
5	9/16" ROUND HEAD SCREW	44	
4	CLEAT		
3	1" FLAT HEAD SCREW FOR CARCASS	3	
2	Plastic Block	4	
1	9/16" flat head screw	8	
NO.	Description	QTY	PICTURE

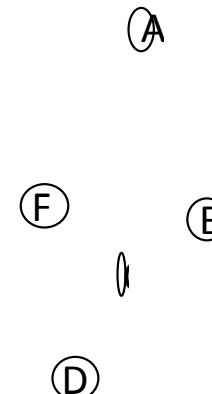
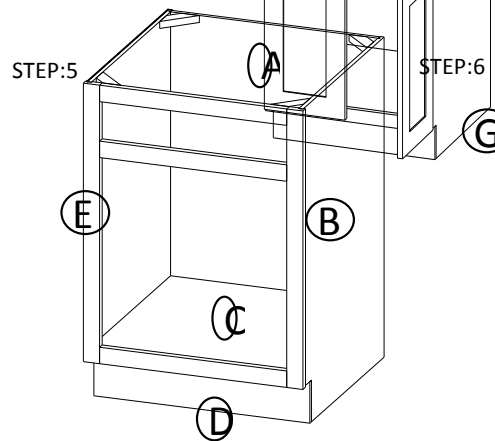
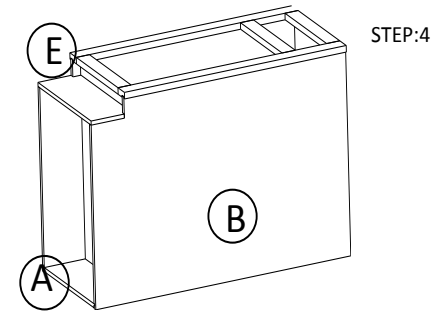
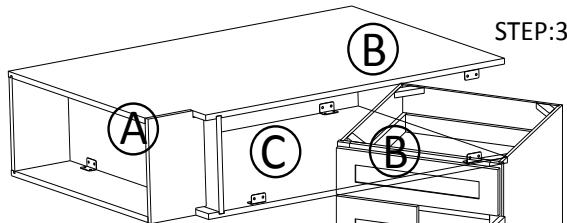
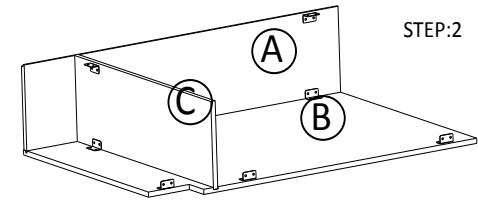
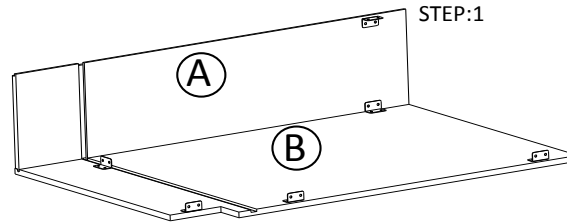

HARDWARE LIST