

VSD36,VSD42,VSD48  
ASSEMBLY INSTRUCTIONS

Getting started:

prepare a protection layer, a screwdriver

STEP 1: Joint side panel with back panel

STEP 2: Joint bottom panel with side panel

STEP 3: Joint side panel with bottom & back panel

STEP 4: Attach frame on and toekick board







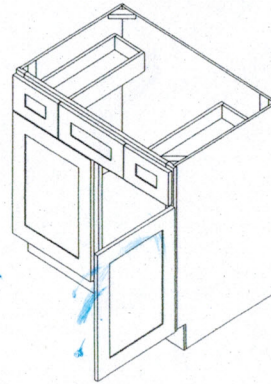





STEP 5: Joint the drawer together, then install the drawer guide.

STEP 6: Attach the wood block on the top corner.

STEP 7: Fix drawer head on the drawer front and fix door onto the frame and adjust the cover-space



PARTS LIST		
NO.	Description	QTY
A	BACK PANEL	1
B	SIDE PANEL	2
C	TOP&BOTTOM PANEL	1
D	TOE KICK	1
E	FACE FRAME	1
F	DRAWER BOX FRONT AND BACK	4
G	DRAWER BOX SIDE	4
H	DRAWER BOX BOTTOM	2
I	DRAWER HEAD	2
J	DRAWER HEAD	1
K	CABINETS DOOR	2

12	HINGE PLATE	2	
11	1 1/2" SOFTCLOSE HINGE	4	
10	3/4" ROUND HEAD SCREW	4	
9	BUMPER	12	
8	DAMPER	2	
7	1" ROUND HEAD SCREW	8	
6	Selfclose slider	2	
5	9/16" ROUND HEAD SCREW	44	
4	CLEAT	11	
3	1" FLAT HEAD SCREW FOR CARCASS	5	
2	WOOD BLOCK	4	
1	1" FLAT HEAD SCREW FOR WOOD BLOCK	8	
NO.	Description	QTY	PICTURE

HARDWARE LIST

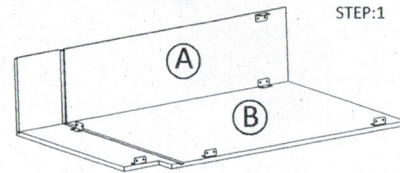

STEP:1

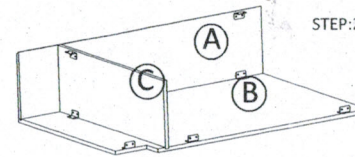

STEP:2

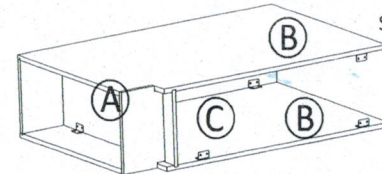

STEP:3

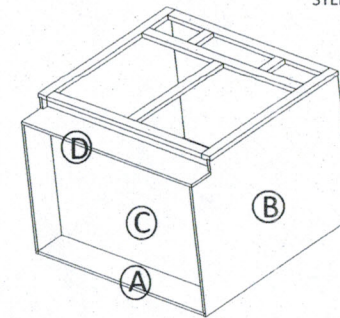

STEP:4

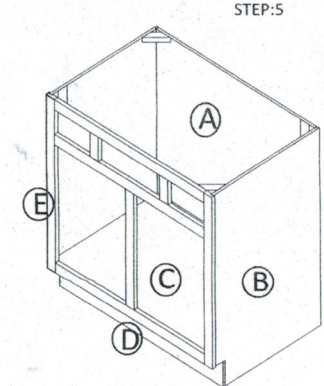

STEP:5

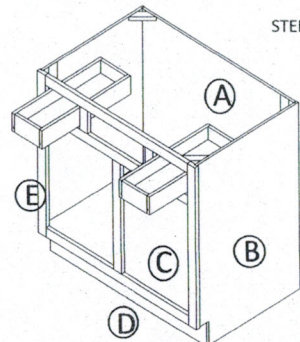

STEP:6

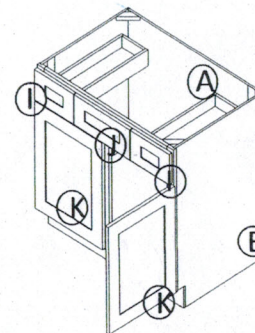

STEP:7

Full extension concealed drawer runners

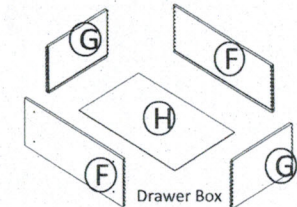
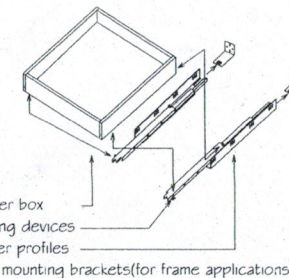

Drawer Box

How To Fix Soft Close Hinge

