

**WBC2730,WBC2736,WBC2742**

**ASSEMBLY INSTRUCTIONS**

**Getting started:**

prepare a protection layer, a screwdriver

STEP 1: Joint side panel with back panel

STEP 2: Joint top panel with side panel

STEP 3: Joint bottom panel with side panel





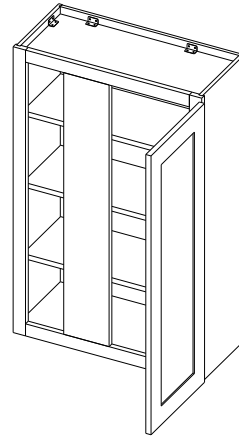

STEP 4: Attach frame on

STEP 5: Put on the adjustable shelves

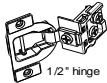
STEP 6: Fix door onto the frame and adjust the cover-space

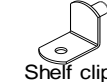

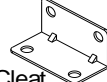
PARTS LIST		
NO.	Description	QTY
A	SIDE PANEL	2
B	BACK PANEL	1
C	TOP&BOTTOM PANEL	2
D	FACE FRAME	1
E	ADJUSTABLE SHELF	2
F	CABINETS DOOR	1

7	1/2" HINGE	2	
6	3/4" ROUND HEAD SCREW	2	
5	BUMPER	2	
4	SHELF CLIP	8	
3	9/16" ROUND HEAD SCREW	56	
2	CLEAT	14	
1	1" FLAT HEAD SCREW FOR CARCASS	6	
NO.	Description	QTY	PICTURE

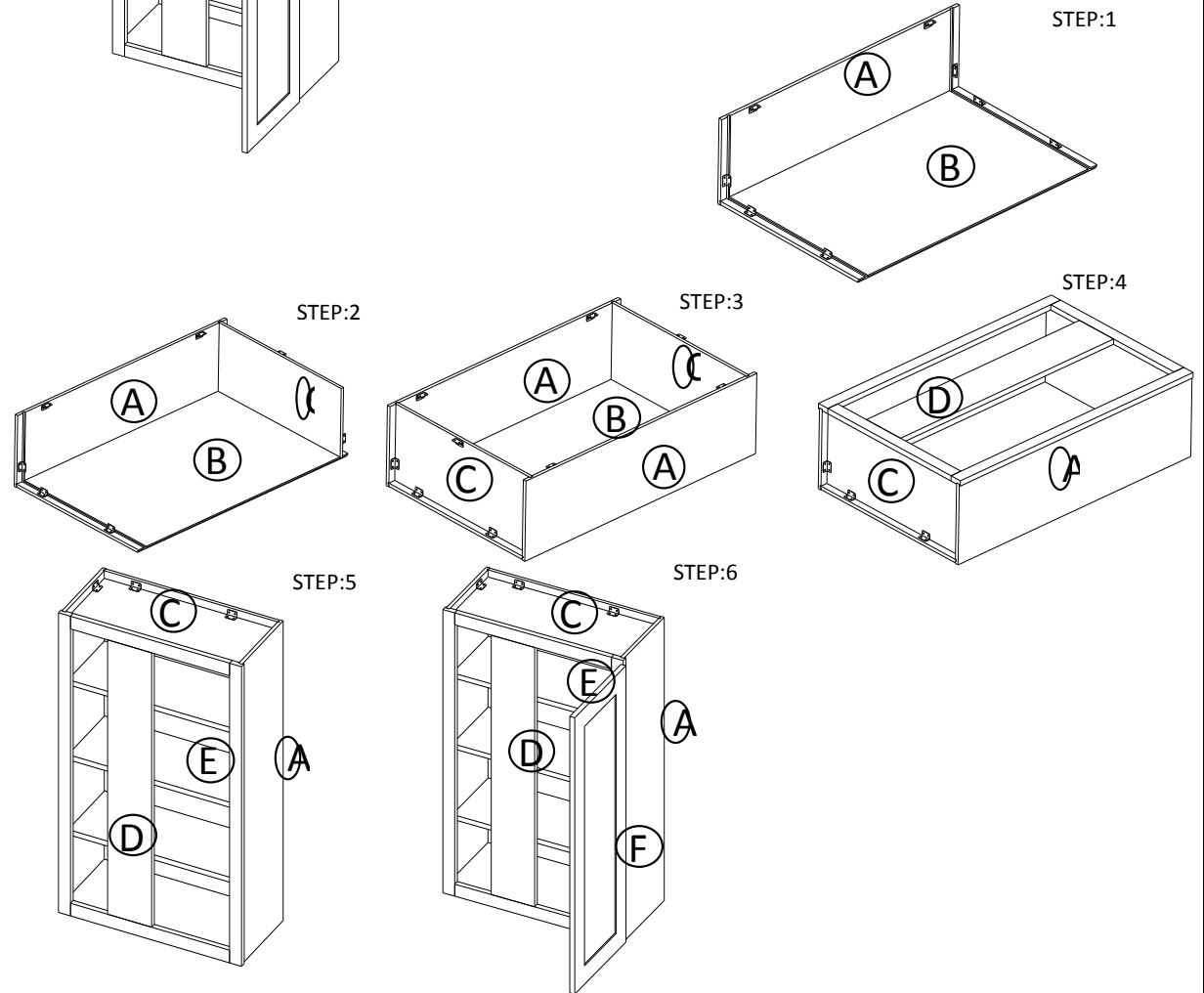

**HARDWARE LIST**