

WRC2430,WRC3018

ASSEMBLY INSTRUCTIONS

Getting started:

prepare a protection layer, a screwdriver

STEP 1: Joint side panel with back panel

STEP 2: Joint top panel with side panel

STEP 3: Joint bottom panel with side panel

STEP 4: Attach the wine rack on the both side

STEP 5: Attach front face frame on

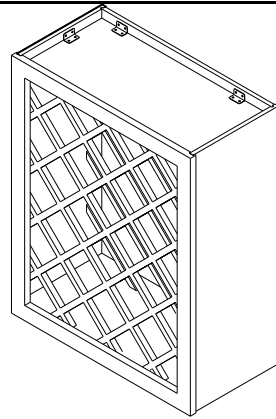

PARTS LIST		
NO.	Description	QTY
A	BACK PANEL	1
B	SIDE PANEL	2
C	TOP&BOTTOM PANEL	2
D	WINE RACK	2
E	FACE FRAME	1

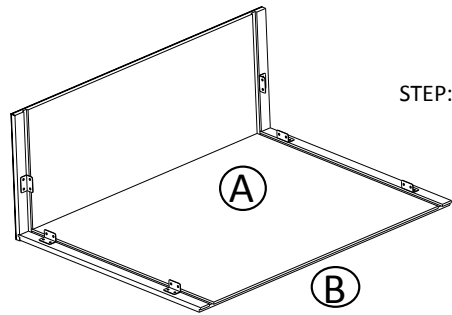

STEP:1

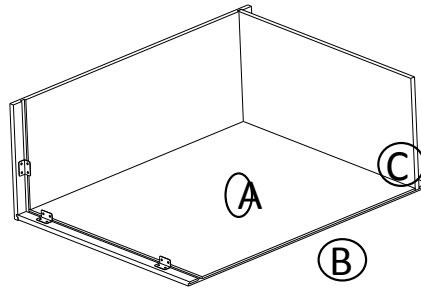

STEP:2

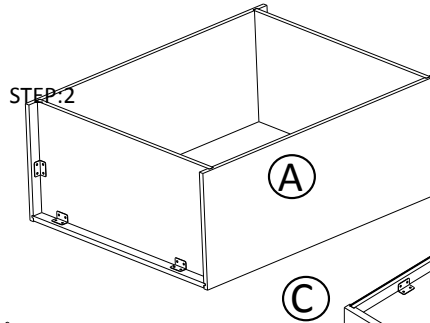

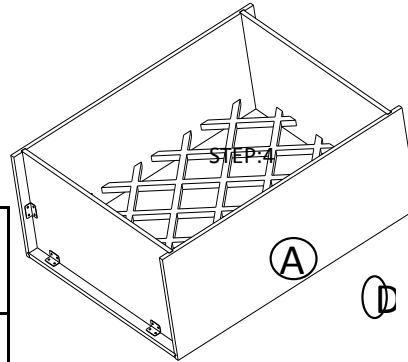

STEP:3

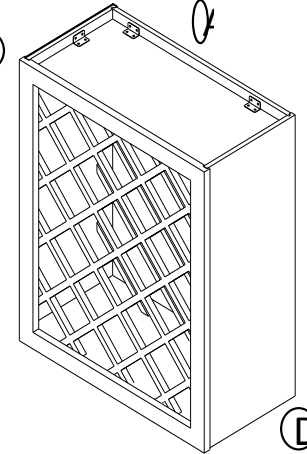

STEP:4

STEP:5

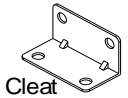
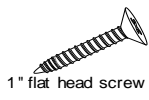

3	9/16"ROUND HEAD SCREW	48	 9/16" round head screw
2	CLEAT	12	 Cleat
1	1"FLAT HEAD SCREW FOR CARCASS	12	 1" flat head screw
NO.	Description	QTY	PICTURE

HARDWARE LIST